

## Key Features

The key features of the GTX433M-3V-A00S06A-M27A transmitter module are:

- Carrier frequency of 433 Mega Hertz
- Supports Amplitude Shift Keying (ASK) modulation with 90dB modulation depth
- Supports 3.3V input digital data (0 – 3.3V)
- Supports two modes of operation: power down and power up
- Transmit bit rate up to 100Kbps
- Supply voltage range of 2.1 to 3.6 for 3.3V technology
- Supports a low 5.7mA supply current
- Operating temperature range of -40 to 125 degrees
- Antenna matching input of 50 ohms
- Low power consumption
- SIP package of 6 pins with 100 mil spacing between pins
- Module dimensions are 1.125 inches wide by 0.75 inches height

## Targeted Applications

Some of the targeted applications of the GTX433M-3V-A00S06A-M27A transmitter are:

- Remote controlled garage door openers
- Remote controlled robotics
- Remote keyless entry systems
- Remote controlled toys
- Wireless sensors
- Wireless computer peripherals
- Wireless security systems
- Wireless game consoles
- Wireless pressure monitoring systems

## Ordering Info

Manufacturer/Distributor	Part Number	Online Store	Sales
WyJen Technologies Incorporated	GTX433M-3V-A00S06A-M27A	www.wyjen.com	1-800- 490-4165

## Description

The GTX433M-3V-A00S06A-M27A transmitter module input/output pin information is shown in Figure 1 and their corresponding descriptions are given in Table 1. As shown in Figure 1, the GTX433M-3V-A00S06A-M27A is a 6 pin SIP package.



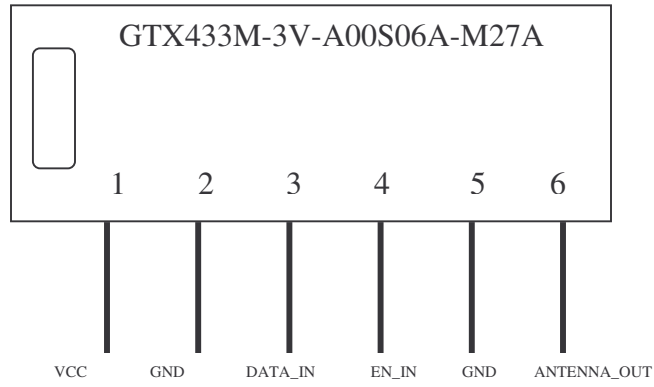

**Figure 1.** Illustration of GTX433M-3V-A00S06A-M27A transmitter module showing inputs and outputs.



The function of each pin is described in the Table 1.

Name	Pin Number	Description
VCC	1	3.3 V power supply.
GND	2	GROUND.
DATA_IN	3	Digital Data input. Power amplifier is on when data input is high (3.3 volts) and off when data input is low (0 volts). Should be 3.3 volt peak to peak..
EN_IN	4	Enable input. Module is in standby mode when this pin is low (0 volts), otherwise a high (3.3 volts) on this input puts the module is in power up mode.
GND	5	GROUND.
ANTENNA_OUT	6	50 ohm antenna output.

**Table 1.** Pin description table for the GTX433M-3V-A00S06A-M27A transmitter module.



### Application Circuits

The application for the GTX433M-3V-A00S06A-M27A circuits are based on whether the application requires 3.3V or 5 volts. These are given next.

#### 3.3 Volt Application Circuit

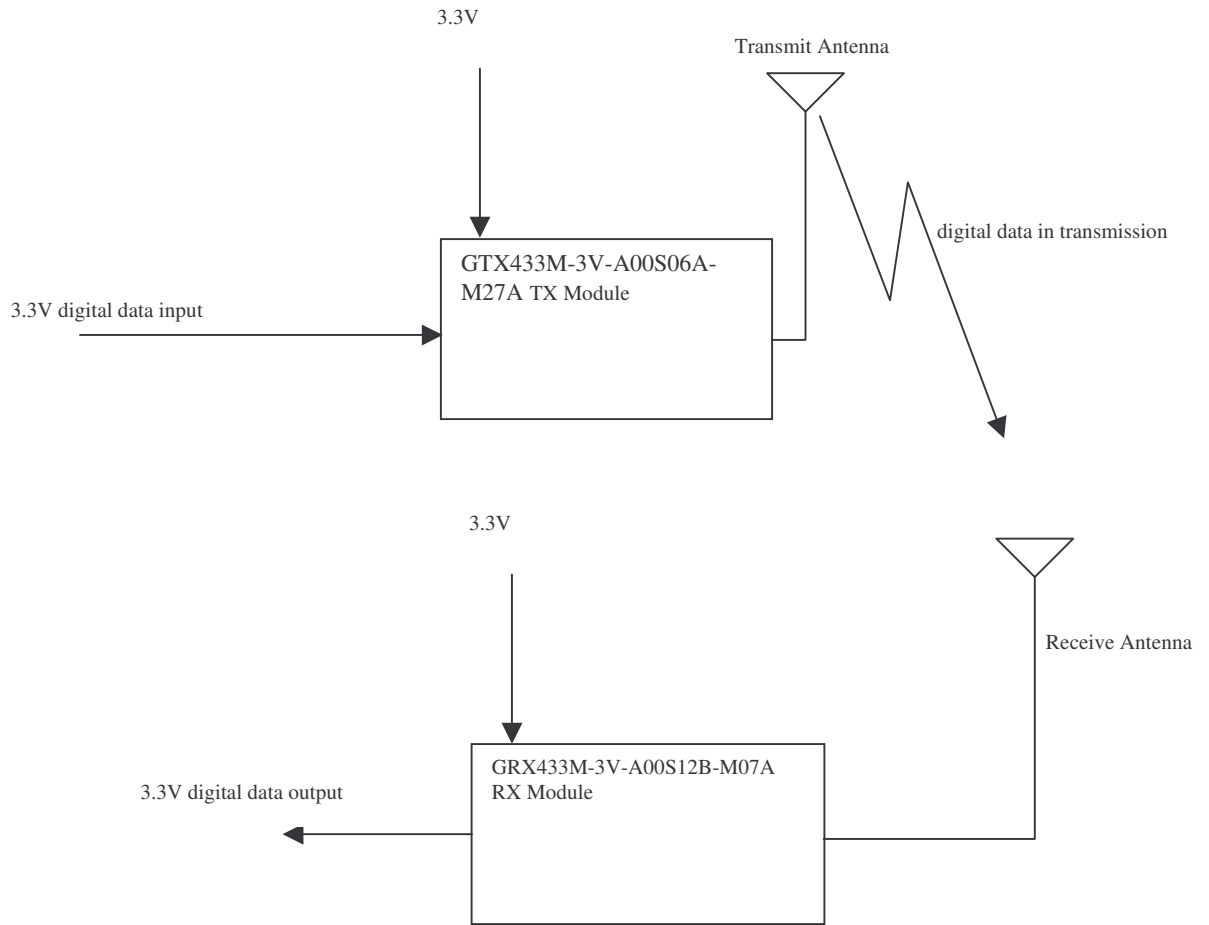

**Figure 2** The GTX433M-3V-A00S06A-M27A transmitter module tested with a GRX433M-3V-A00S12B-M07A receiver module.



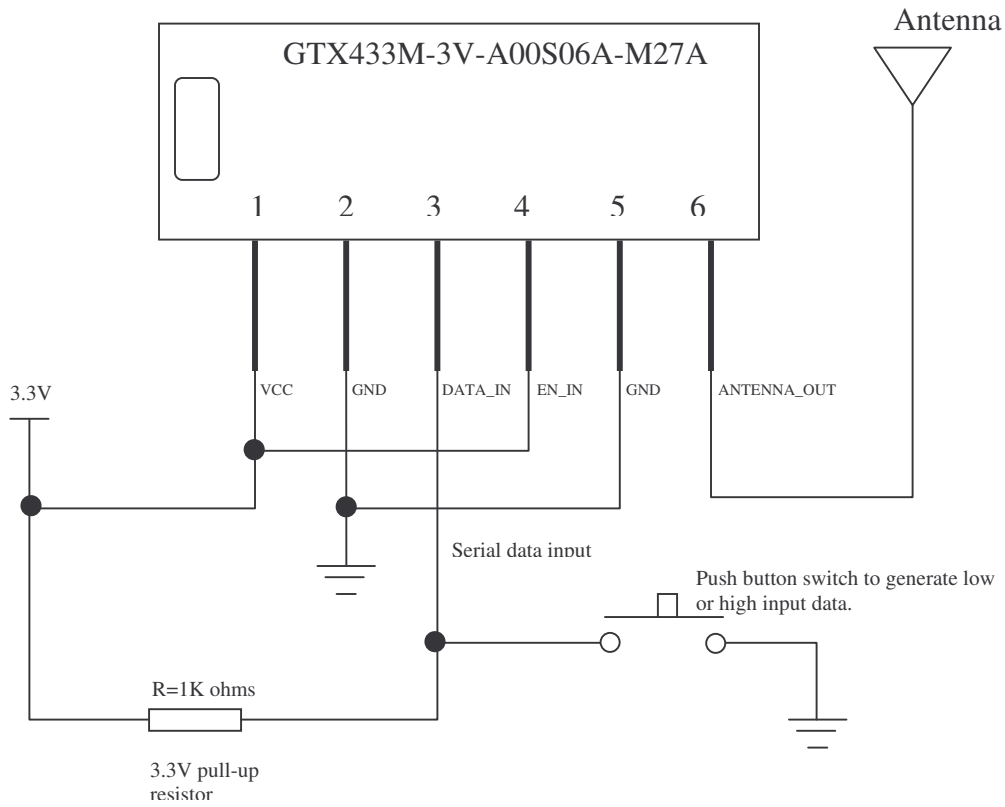

**Figure 3.** Detailed application circuit using the GTX433M-3V-A00S06A-M27A transmitter module for a 3.3V application. The input serial data is simulated by a on/off push button switch.



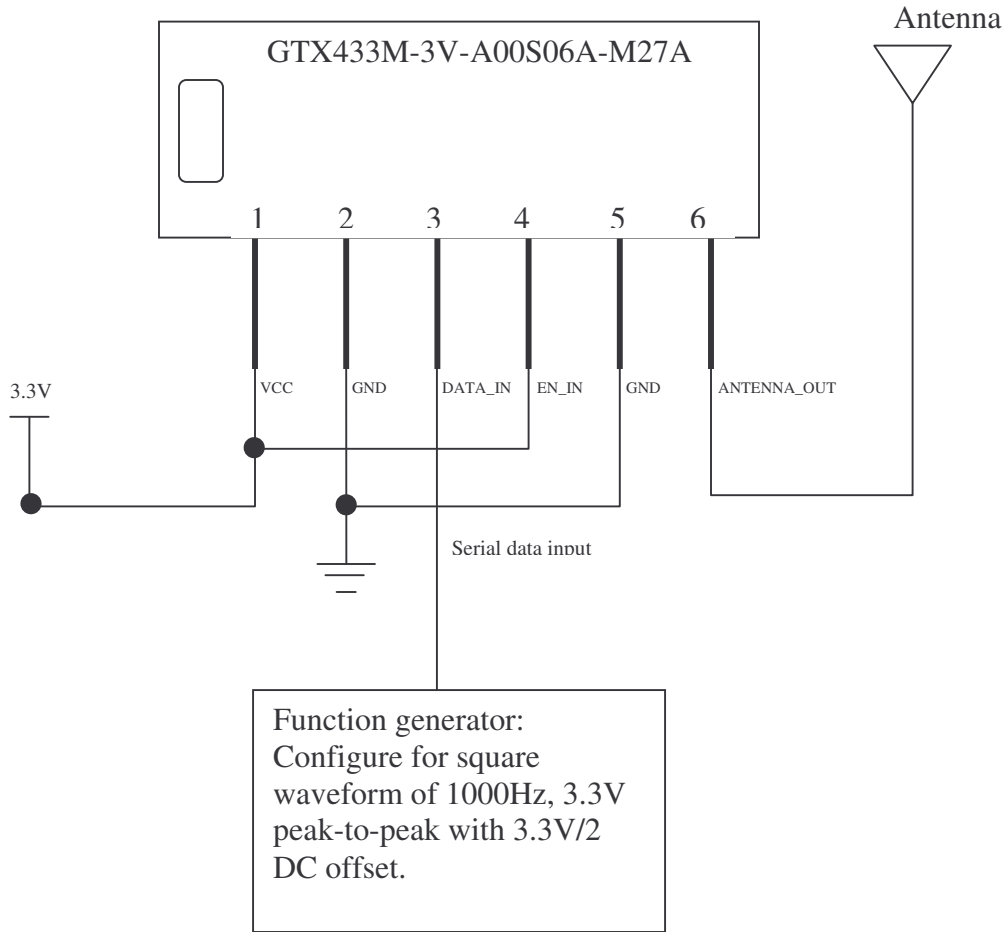

**Figure 4.** Detailed application circuit showing the GTX433M-3V-A00S06A-M27A transmitter module using a 1000Hz, 3.3V peak-to-peak square waveform with 3.3V/2 DC offset to simulate the serial input data in a 3.3V application.



### 5 volt Application Circuit

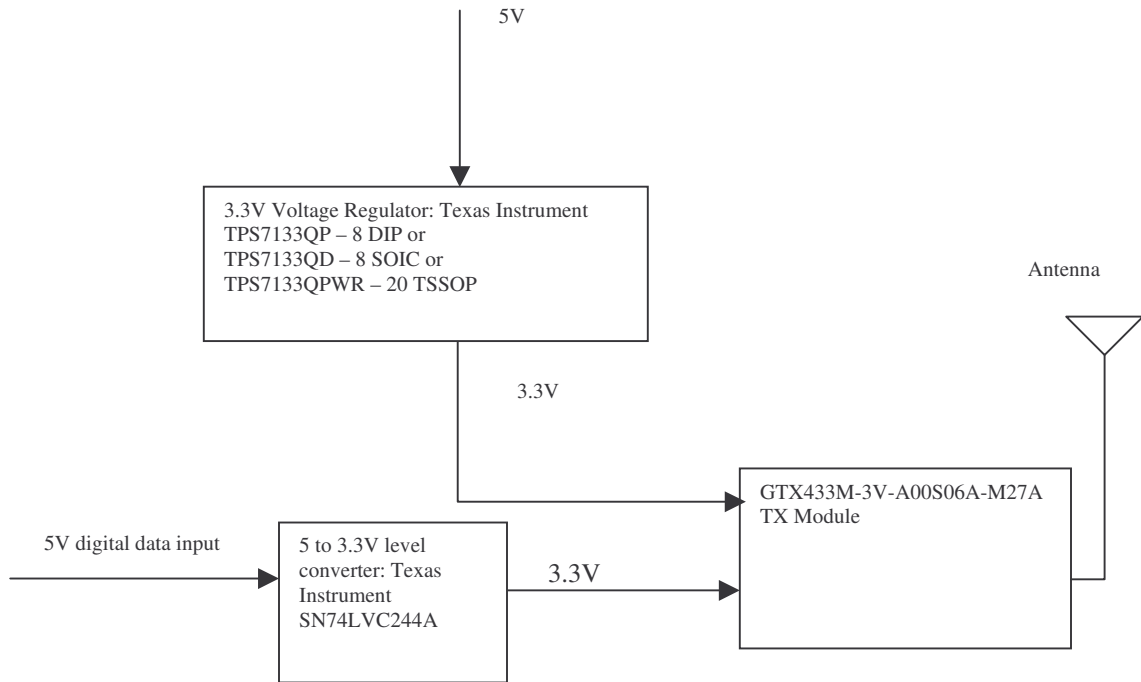
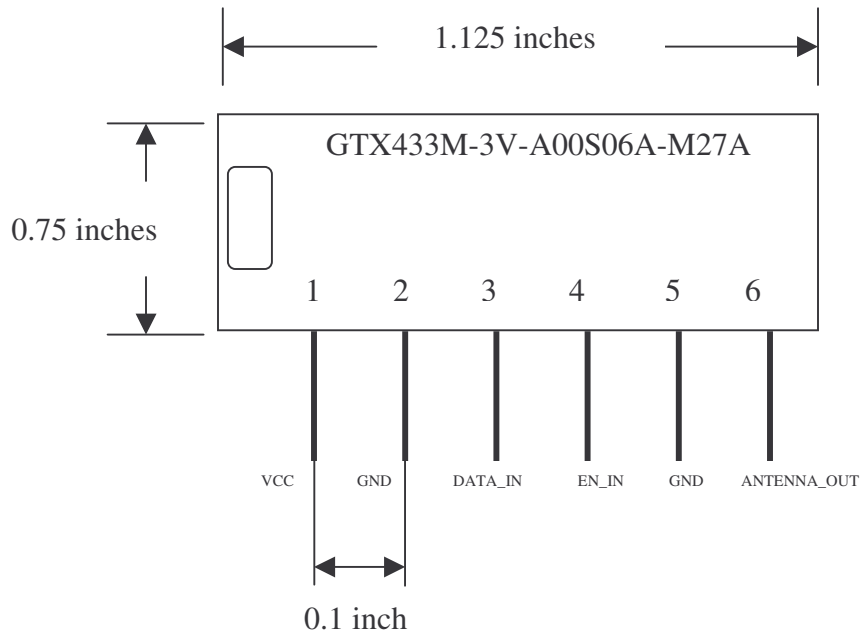

Figure 5. 5V application circuit block diagram.



### **GTX433M-3V-A00S06A-1 Transmitter Module Dimensions**

The actual dimensions for the GTX433M-3V-A00S06A-M27A are given **Figure 6**.



**Figure 6.** Illustration of GTX433M-3V-A00S06A-M27A transmitter module showing dimensions.



## Part Numbering

The part numbering scheme for the WyJen Technologies wireless modules are explained below.

### GAABBBC-XX-YYYZWWT-VVV-U

G	WyJen Technologies Specifier
AA	TX stands for Transmitter RX stands for Receiver TR stands for Transmitter and Receiver
BBB	3 digit number representing carrier frequency 2 digit number representing carrier frequency with decimal point represented by D
C	M stands for mega Hertz G stands for Giga Hertz
XX	5V stands for 5 volt technology 3V stands for 3.3V technology
YYY	A00 stands for ASK modulation F00 stands for FSK modulation P00 stands for PSK modulation Q00 stands for QAM modulation AF0 stands for ASK and FSK modulation AFP stands for ASK, FSK, and PSK modulation AM0 stands for amplitude modulation AFM stands for ASK and FM modulation FFM stands for FSK and FM modulation
Z	S stands for SIP package D stands for DIP package M stands for surface mount package
T	A stands for 1.125 inches width by 0.75 inches height B stands for 2 inches width by 0.75 inches height
WW	2 digit number representing number of input and output pins in the package
VVV	3 character series code
U	1 character feature code

#### Notes:

1. T Field: For SIP package width is side with connector
2. BBB and C Fields are used together: Some example values are
  - 315M
  - 433M
  - 868M
  - 915M
  - 2D5G
  - 5D8G



## Examples

The part number GTX315M-3V-A00S06A-M27A corresponds to a WyJen Technologies transmitter, 315 mega hertz operating frequency, that requires a 3.3 volt power supply, uses amplitude shift keying modulation with a 6 pin SIP package, series M27 transmitter, with version A features. The dimensions of the package are 1.125 width x 0.75 by height.

The part number GTX2D5G-3V-F00S12B-M07A corresponds to a WyJen Technologies transmitter, 2.5 Giga hertz operating frequency, that requires a 3.3 volt power supply, uses frequency shift keying modulation with a 12 pin SIP package, series M07 receiver, with version A features. The dimensions of the package are 2 width x 0.75 by height.

